

(No Model.)

3 Sheets—Sheet 1.

G. E. HUNTER.
DEAD CENTER LATHE.

No. 545,692.

Patented Sept. 3, 1895.

Fig. 1.

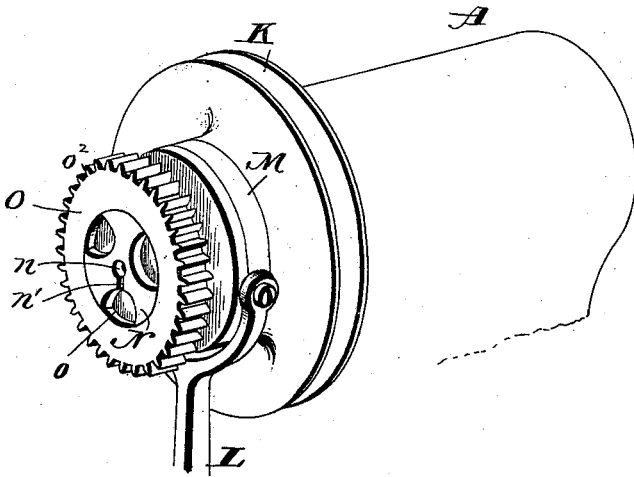
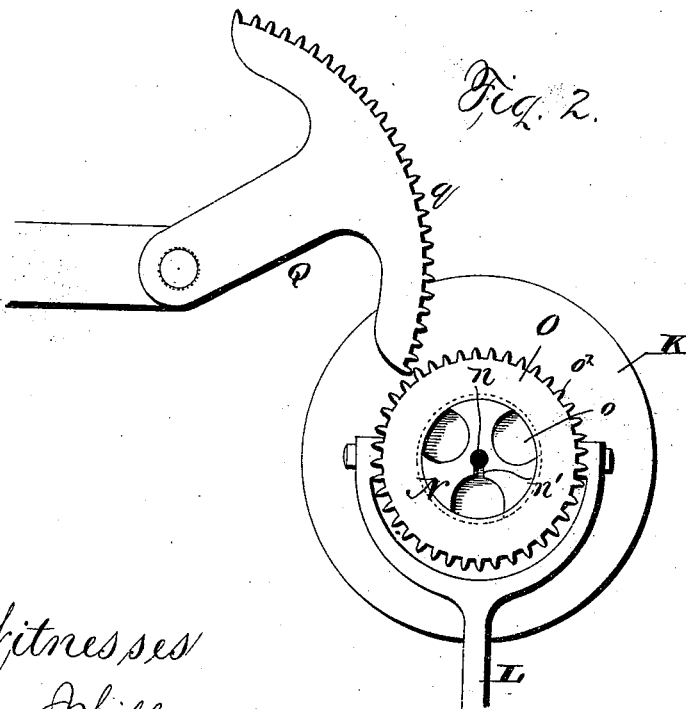

Fig. 2.



Witnesses
Chas. J. Williamson.
Jas. E. Hutchinson.

Inventor
George E. Hunter, by
Kimball and Russell, his Attys.

G. E. HUNTER.
DEAD CENTER LATHE.

No. 545,692.

Patented Sept. 3, 1895.

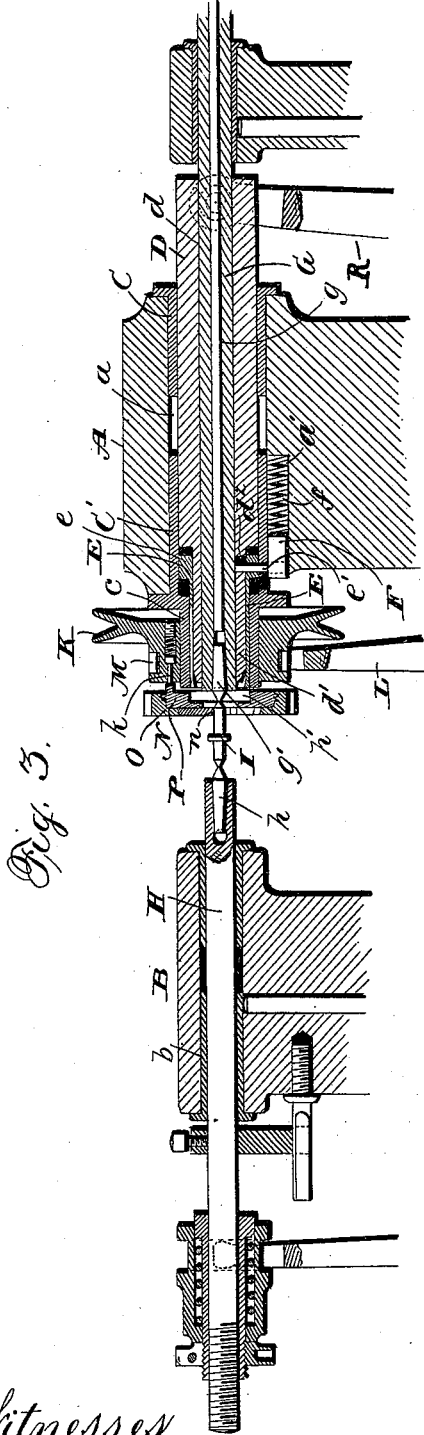

Fig. 3.

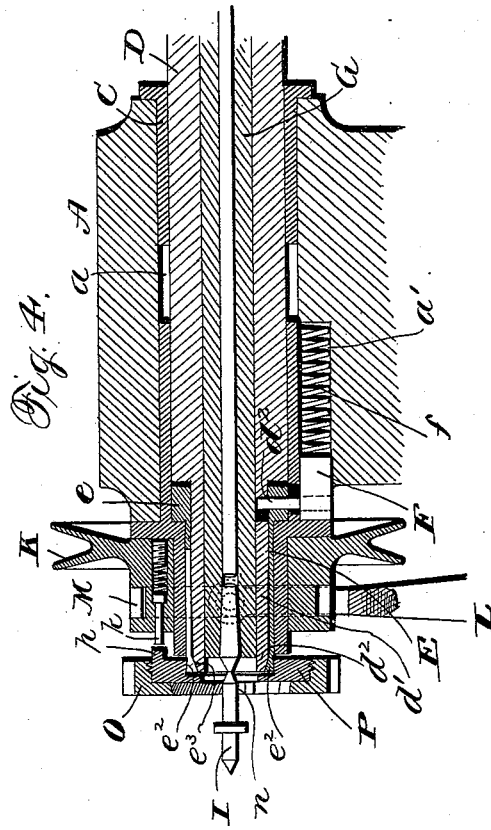

Fig. 4.

Witnesses
Chas. Williamson,
 Jas. Hutchinson.

Inventor
George E. Hunter, by
Pindle and Russell, his Attys

G. E. HUNTER.
DEAD CENTER LATHE.

No. 545,692.

Patented Sept. 3, 1895.

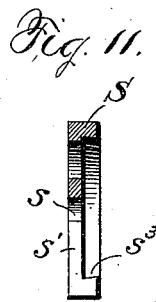
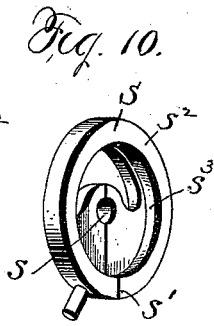
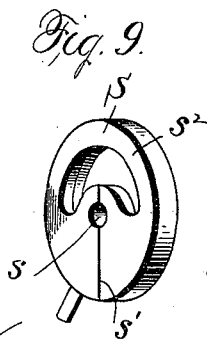
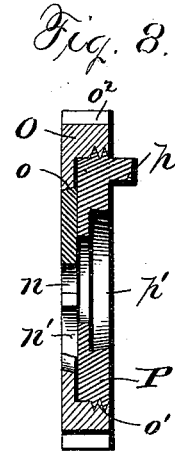
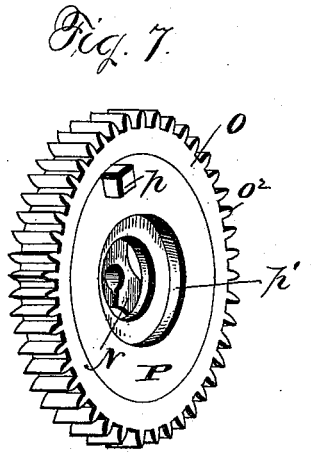
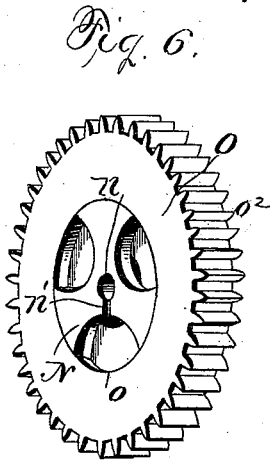
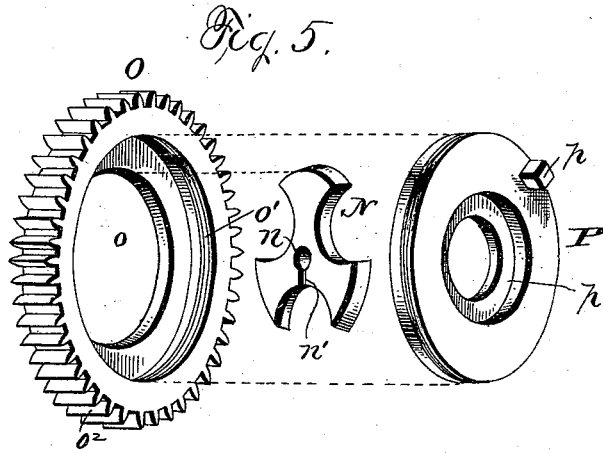

Witnesses
 Chas. Williamson
 Jas. E. Hutchinson.

Inventor
 George E. Hunter by
 Prindle and Russell, his Attys

UNITED STATES PATENT OFFICE.

GEORGE E. HUNTER, OF ELGIN, ASSIGNOR TO THE ELGIN NATIONAL WATCH COMPANY, OF CHICAGO, ILLINOIS.

DEAD-CENTER LATHE.

SPECIFICATION forming part of Letters Patent No. 545,692, dated September 3, 1895.

Application filed August 2, 1893. Serial No. 482,170. (No model.)

To all whom it may concern:

Be it known that I, GEORGE E. HUNTER, of Elgin, in the county of Kane, and in the State of Illinois, have invented certain new and useful Improvements in Dead-Center Lathes; and I do hereby declare that the following is a full, clear, and exact description thereof, reference being had to the accompanying drawings, in which—

Figure 1 is a perspective view of the head portion of my lathe from the front or work-holding end. Fig. 2 is a front elevation of the same, showing the means employed for closing and releasing the clamp-dog. Fig. 3 is a central longitudinal section of the lathe, the parts being shown in position for the rotation of the work. Fig. 4 is a like view of the head portion of said lathe, showing the relative positions of parts when arranged for closing or releasing the clamp-dog. Fig. 5 is an enlarged perspective view of the parts or said dog separated from each other. Figs. 6 and 7 are like views of the same from the front and rear, respectively, when united for use. Fig. 8 is a section of said dog upon a central axial line. Figs. 9 and 10 are enlarged perspective views from the front and rear, respectively, of a collapsing or self-closing dog; and Fig. 11 is a central section of the same.

Letters of like name and kind refer to like parts in each of the figures.

The object of my invention is to enable work to be easily and quickly dogged for manipulation in dead-center lathes; and my said invention consists in the construction of the dogging device, substantially as and for the purpose hereinafter specified.

In the carrying of my invention into practice I employ an ordinary lathe-bed, from which extends upward a head-stock A and a tail-stock B, that are provided with coinciding axial openings a and b , respectively. Within the head-stock opening a are fitted two bushings C and C', of which the rear bushing C has the usual form, while the front bushing C' extends beyond the end of the head-stock, and such extension c has an external diameter substantially equal to the interior diameter of the rear or main portion of such bushing.

Fitted into and adapted to slide longitudinally within the bushings C and C' is a plunger D, which interiorly is provided with a straight round axial opening d and at its front end has a section d' , that is somewhat smaller in external diameter than the interior diameter of the extension c of the bushing C', and upon such section has fitted a split sleeve E, which fills the space between such parts, and at its rear end is provided with a collar e , that corresponds in diameter to and fills the interior of said bushing in rear of its said extension. Said sleeve is connected circumferentially with said plunger by means of a stud e' , which passes radially through the collar e into an opening d^2 in said plunger, which opening is elongated in a line with the axis of the latter, so as to permit of a certain amount of independent longitudinal motion of the same. From said collar said stud projects radially into a plunger F, that is contained within a corresponding recess a' in the head-stock A, and, by means of a spring f , which is placed between its rear end and the rear end of said recess, operates to hold said plunger and said sleeve with a yielding pressure at the front limit of their motion.

Within the axial opening d of the plunger D is a spindle G, which has an axial opening g and within its front end carries a center g' , of usual form. Said spindle, while capable of longitudinal motion, is ordinarily locked in place both longitudinally and circumferentially. A similar spindle H, fitted into the tail-stock B, carries within its inner end a center h and by any suitable means is adapted to be moved longitudinally, so as to cause said center to engage with the end of a center-staff blank I or other part to be operated upon, and, in connection with said center g' , furnish for the same a pivotal support. Said spindle is preferably moved rearward by a positive means, while in a forward direction it is adapted to yield to any obstruction.

Journalled upon the extension c of the bushing C is a whirl K, of usual construction, which is adapted to be rotated thereon by means of a belt or cord, and is capable of being moved lengthwise of such extension by means of a lever L, that at its upper forked end engages

with opposite sides of a ring M, which is journaled upon or near the front end of such whirl. A stud k , projecting forward from the latter and held with a yielding pressure at the front limit of its longitudinal motion, furnishes a means whereby said whirl may be caused to engage with a dog upon the blank I and give its rotary motion to the latter.

The dog N preferably employed consists, essentially, of a disk provided with a suitable axial opening n and having at one side a radial cut n' , that permits of compression in the usual way. The periphery of such dog is tapering, and it is fitted into a correspondingly-shaped central opening o , which is provided in a ring O, the construction being such that if said dog is pressed forward within said ring-opening it will be compressed upon and caused to grip the blank I. Such result is secured by enlarging and threading the rear portion o' of the opening o and fitting into the same a peripherally-threaded disk P, which, when screwed inward, presses upon the rear face of said dog and forces the latter into said tapering opening. A stud p , projecting rearward from said disk, furnishes a means whereby the stud k of the whirl K may engage with and rotate the dog and its work.

In order that the dog may be easily opened and the work changed, the rear side of the disk P is provided with a circular recess p' , which increases slightly in diameter from its rear to its front end, and upon the front end of the sleeve E is formed a corresponding oppositely-inclined part e^2 , that is capable of entering such recess. The interior of said sleeve from near its front end outward has a section e^3 , which decreases in diameter, and upon the front end of the plunger D is provided a corresponding opposite incline d^2 , that when said plunger is moved forward operates to spread the front end of said sleeve, so as to cause it to fill said recess p and firmly engage it with said disk. When thus engaged, the ring O may be turned so as to unscrew it from the disk and permit the dog to expand and release the blank, after which another blank may be inserted and said dog closed upon the same.

For the purpose of opening and closing the dog I preferably provide the periphery of the ring O with gear-teeth o^2 , and to or upon some stationary support pivot a lever Q, which upon its end carries a toothed segment q , that by a movement of said lever upon its pivotal bearing is adapted to engage with and rotate said ring, the arrangement being such that by a downward movement of said segment said dog will be released, while by the return upward movement it will be closed. The longitudinal movements of the plunger D are preferably effected by means of a bar R, which has its upper forked end pivoted upon opposite sides, at the rear end of the same.

In practice it is intended that all of the op-

erations described shall be automatically effected in due order, so that the apparatus will require nothing but mere supervision; but each operation may be separately effected by the operator, if desired.

For some purposes the dog shown in Figs. 9, 10, and 11 may be employed, if preferred. Said dog consists of a disk S, which is provided with a central opening s , from which a cut s' extends radially to the periphery. The portion opposite to said cut is cut away, as shown, so as to form of the remaining metal a spring s^2 , that enables the cut part to be sprung apart and the opening s to be expanded, after which, by releasing said cut part, the disk will resume its normal position and by inward spring closely grasp a blank previously inserted within said opening. The rear face of said dog is provided with a recess s^3 , which is like the recess p of the disk P and receives the end e^2 of the sleeve E, so that by the action of the plunger D the expansion of said sleeve will cause a like expansion of said dog.

It will be observed that the dog is attached to the lathe only temporarily by the engagement of the sleeve E, and after being secured to the work it is supported entirely by the latter. In view of this when a change in the dog is desired, as where work of one size is to be operated upon instead of another, the dog will automatically drop out of the machine simply by the operator omitting to insert a new blank at the proper time. It is therefore unnecessary to take any portion of the machine apart or to touch the dog to be removed.

It will be seen that, if desired, the devices shown may be used for the purpose of dogging blanks and the latter then placed in and turned by any dead-center lathe.

Having thus described my invention, what I claim is—

1. As an improvement in means for rotating blanks or work in lathes, the combination of suitable centers, a dog, a support for the dog which is disengaged therefrom when the dog is attached to the work, and means made separate from the dog for rotating the same, substantially as and for the purpose specified.

2. As an improvement in means for rotating blanks or work in lathes the combination of suitable centers, for the work, a dog, a support for the latter which is separated from it when the dog is attached to the work, and a whirl for rotating the dog made separate therefrom, substantially as and for the purpose shown.

3. As an improvement in means for rotating blanks or work in lathes, the combination with the work-holding device having a recess in one face, of the lathe part, movable into the recess to engage and support said device, and out of the same to release the device when it is attached to the work, substantially as and for the purpose set forth.

4. As an improvement in means for rotating blanks or work in lathes, the combination of the spring dog, the two-part clamping device, and the lathe part for detachably engaging and supporting said device, substantially as and for the purpose specified.

5. As an improvement in means for rotating blanks or work, the combination of the spring dog, having a tapering periphery and the clamping device comprising two parts, one of which is rotatable relative to the other part, and has an opening conforming to the tapering periphery of the dog, substantially as and for the purpose described.

6. As an improvement in means for rotating blanks or work, the combination of the spring dog and the clamping device comprising two parts, one of which is rotatable relative to the other part and said other part has provision for engagement by a support, substantially as and for the purpose shown.

7. The combination of suitable work holding centers, an expansible sleeve to engage a dog, a plunger to expand said sleeve, and a whirl to engage and rotate such dog, when freed from the sleeve, substantially as and for the purpose shown and described.

8. As an improvement in means for rotating blanks or work, the combination with suitable work holding centers, a whirl for revolving the work having a projection adapted for engagement with and disengagement from a

dog that is secured to the work held by the centers, and a support for the dog adapted for connection with and separation from the same substantially as and for the purpose specified.

9. As an improvement in means for rotating blanks or work, the combination with suitable work holding centers, of a whirl for revolving the work movable into and out of engagement with a dog that is secured to the work held by the centers, and a support for the dog adapted for connection with and separation from the same substantially as and for the purpose described.

10. As an improvement in means for rotating blanks or work, the combination with suitable work-holding centers, a dog for attachment to the work held by the centers, having a lug or projection, a support for the dog adapted for connection with and separation from the same, and a whirl movable toward and from the dog to place a part carried by and projecting from it into and out of engagement with the lug on the dog, substantially as and for the purpose shown.

In testimony that I claim the foregoing I have hereunto set my hand this 20th day of June, 1893.

GEORGE E. HUNTER.

Witnesses:

GEO. S. PRINDLE,
CARLOS H. SMITH.